

NEGATIVE GLOW DISPLAY

Filed March 26, 1937

Fig. 1

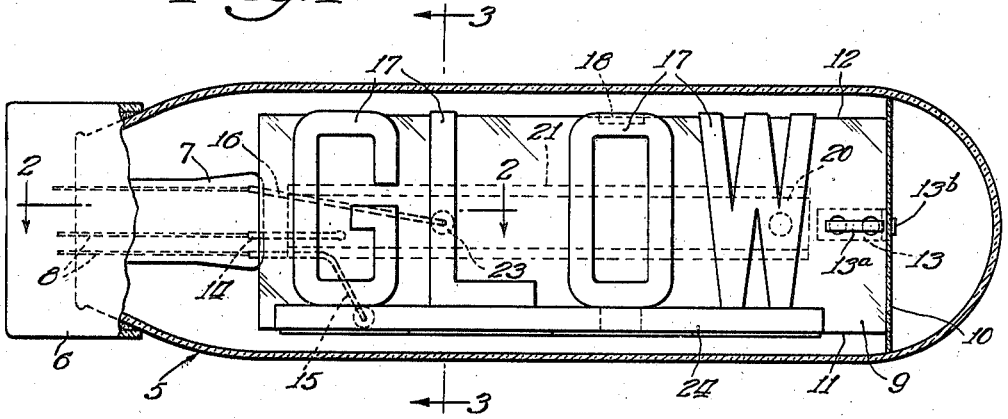

Fig. 2

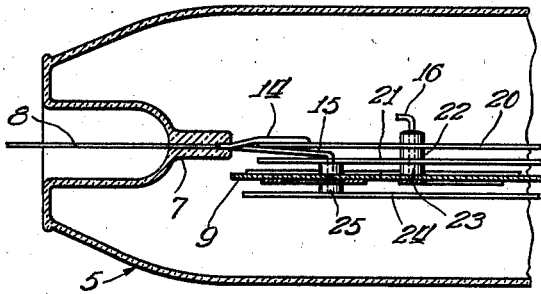

Fig. 3

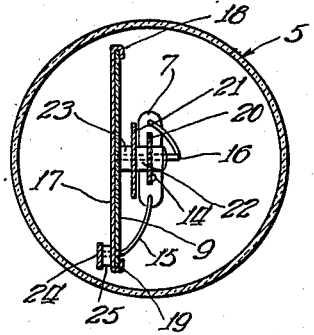

Fig. 4

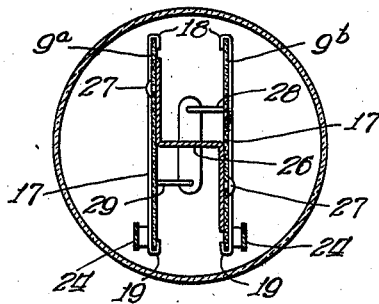
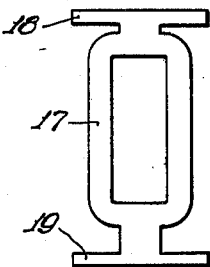

Fig. 5



Inventor:
 Andrew F. Henninger, Jr.
 By: Zabel Carbon & Wells.

UNITED STATES PATENT OFFICE

2,108,487

NEGATIVE GLOW DISPLAY

Andrew F. Henninger, Jr., Chicago, Ill.

Application March 26, 1937, Serial No. 133,198
In Canada April 11, 1936

7 Claims. (Cl. 176—14)

The present invention relates to negative glow display devices and particularly to an improved method of construction therefor having certain advantages over that shown in my Patent No. 2,069,308.

In the above application, I have disclosed a structure wherein the necessity for use of support wires to brace the electrodes is to a substantial degree overcome. The structure as disclosed in the previous application is one in which a flat or curved sheet of mica or other suitable material is made of such a size as to position the electrodes supported thereby within the tube without further mounting means.

The present invention relates to certain improvements which have been found to be advantageous for some of the constructions of display devices. The present invention contemplates the provision of a plurality of sheets of mica supporting structure for negative glow electrodes in which the mica sheets directly supporting the electrodes may be spaced from the walls of the glass tubes. With the improved construction, it is possible to connect the electrodes more readily, and valuable flaming effects over the edges of the mica sheets may be obtained.

I will describe a preferred form of the invention by reference to the accompanying drawing. It is to be understood, however, that the drawing and description are illustrative only and are not to be taken as limiting the invention except in so far as it is limited by the claims.

In the drawing:

Figure 1 is a longitudinal sectional view through a negative glow tube embodying the invention.

Figure 2 is a plan section taken on the line 2—2 of Figure 1.

Figure 3 is a sectional view taken on the line 3—3 of Figure 1.

Figure 4 is a sectional view similar to Figure 3 of a slightly modified form of the invention, and

Figure 5 is a side view of an electrode used in the present construction.

Referring now in detail to the drawing the numeral 5 indicates the usual negative glow tube. A base 6 is provided on the tube for making the necessary connections as will be readily understood. The tube 5 has a reentrant stem 7 in which suitable conductors 8 are secured. The tube 5 has a filling of a suitable gas as described in my prior application.

The tube 5 has a supporting structure therein composed of a longitudinally running sheet 9 of mica and a sheet 10 fitting snugly in the tube 5

at the end of the tube opposite the press 7. The sheet 9 may have its side edges 11 and 12 spaced from the tube 5. It is held in position by a bracket 13 which is fixed to the sheet 10. The bracket 13 is an L-shaped metal strip. Holes are provided in the sheets 9 and 10. A pair of small metal strips 13a and 13b are welded to the strip 13 in the holes and project over the adjacent portions of the sheets 9 and 10. The mica sheet 9 may be supported directly from the glass 5 at the end opposite the sheet 10 or it may be supported by means of lead wires 14, 15 and 16 as shown in Figures 1 and 2.

A plurality of electrodes 17, which are shown in the form of letters, are formed from a metal sheet by stamping, etching, or sawing the design. The electrodes are mounted on the front side of the sheet 9 by means of extensions 18 at the top and 19 at the bottom edges of the electrodes. The extensions 18 and 19 project beyond the edges of the sheet 9 and are bent over the edges to thereby secure the metal electrodes to the sheet 9. Each of the letters 17 may be independently connected to a conducting lead 16. I prefer however, to so form each letter or design that the extensions 18 and 19 may extend longitudinally of the sheet 9, a distance sufficient to overlap or connect to the longitudinal extension 18 or 19 of the next adjacent letter or design to thereby electrically connect all of the letters. In order to secure good electrical contact, the entire design may be formed in one piece or the longitudinal extensions 18 and 19 of adjacent letters may be welded together. A back electrode consisting of an elongated sheet 20 is connected to the lead 14. A metal shield 21 is interposed between the mica sheet 9 and the electrode 20, and this sheet is preferably insulated from the sheet electrode 20 by insulating washers 22 which serve to space the shield 21 and the electrode 20 apart. Insulating washers 23 also space the shield 21 from the mica sheet 9.

In front of the mica sheet 9 and spaced from the letters 17 is a front electrode 24 consisting of an elongated metal strip spaced from the mica sheet by suitable insulating washers 25. The front electrode 24 is connected to a lead 15 by which it may be connected to a source of current. If lead 15 is disconnected from a source of current, then electrode 24 will merely act as a silhouette or shield.

The fact that the longitudinal edges of the plate 9 are spaced a distance from the inside surface of the tube 5 provides a restricted passage for electrons flowing around the edges of

the plate 9. Thus when the electrons pass between the electrodes 17 and the electrode 20 a flaming effect is produced around the edge of the sheet 9. A variation in this flaming effect is readily produced by cutting the electrodes 17 out of circuit and placing electrode 24 in circuit. The sheet 10 which conforms in outline substantially to the inside shape of the tube 5 supports the sheet 9 at the free end and prevents the electrodes carried by the sheet 9 from contacting with the tube 5.

In the course of evacuating the tube 5, it is heated by means of a bombarder in a manner well known in this art. This heating may cause the metal electrodes to expand substantially and in order to prevent permanent warping of electrodes after the heating has discontinued and the tube has cooled, the sheet 10 should be sufficiently thin to allow it to bend during the heating operation in case the electrodes press against it. It has been found that if mica is used for the sheet 10 the thickness of the mica sheet should preferably be about .008 inch.

It will be noted that the shield 21 is slightly larger than the electrode 20 so that as one is looking at the envelope in the direction as it is shown in Figure 1, the electrode 20 cannot be seen but the glowing effect is readily seen at the edges of the shield 21. The portions 18 and 19 which are bent over the edges of the sheet 9 are preferably covered with an insulating cement or varnish.

In the device shown in Figure 4 a double sided sign is produced. In this form a metal backing 25 which is bent in a step formation is used to support a plurality of mica sheets 9a and 9b. The backing 26 need not be of this particular formation but it provides an advantageous construction. The mica sheets 9a and 9b and the sheet 10 may be desirably secured to the backing 26 by metal tabs 27 which pass through holes punched in the mica sheets and are welded to the backing 26. The electrodes 17 are rounded on the outside of the sheets 9a and 9b. Also sheets 24 may be used in this form of the device as well as in the form shown in Figures 1, 2 and 3. Electrical connection is made to the electrodes 17 by a plurality of leads 28 and 29. The portions 18 and 19 of the electrodes 17 are preferably covered with insulating cement. Also the leads 28 and 29 as well as the leads 14, 15 and 16 should be covered with insulating cement.

From the above description it is believed that the construction and advantages of this device will be readily apparent to those skilled in this art. Having thus described my invention what I claim as new and desire to secure by Letters Patent is:

1. In a negative glow device, an envelope, a plurality of electrodes in said envelope, a dielectric sheet of substantial area within said envelope, said sheet having the electrodes mounted thereon whereby the sheet provides the principal support for said electrodes, a press within said envelope, terminals extending from said press, means for electrically joining the electrodes and the terminals, a supporting member of insulating material within said envelope and engaging the inner wall thereof, said supporting member being arranged transversely of the dielectric sheet, the dielectric sheet being supported by said member.

2. In a negative glow device an elongated en-

velope, a plurality of electrodes in said envelope, a dielectric sheet of substantial area within said envelope, said sheet having the electrodes mounted thereon whereby the sheet provides the principal support for said electrodes, a press within said envelope, at the one end thereof terminals extending from said press, means for electrically joining the electrodes and the terminals, a supporting member of insulating material within said envelope and engaging the inner wall thereof, adjacent the end of said envelope remote from the press, said supporting member being arranged transversely of the dielectric sheet, the dielectric sheet being supported by said member.

3. In a negative glow device, an envelope, a plurality of electrodes in said envelope, a dielectric sheet of substantial area within said envelope, said sheet having the electrodes mounted thereon whereby the sheet provides the principal support for said electrodes, a press within said envelope, terminals extending from said press, means for electrically joining the electrodes and the terminals, a thin dielectric disk in said envelope remote from said press and extending transversely of the dielectric sheet, said disk engaging the inner wall of the envelope and said dielectric sheet being fixed to the disk and thereby held in position in said envelope.

4. In a negative glow device, an envelope, a plurality of electrodes in said envelope, a dielectric sheet of substantial area within said envelope, said sheet having the electrodes mounted thereon whereby the sheet provides the principal support for said electrodes, a press within said envelope, terminals extending from said press, means for electrically joining the electrodes and the terminals, a thin dielectric disk in said envelope remote from said press and extending transversely of the dielectric sheet, said disk engaging the inner wall of the envelope and said dielectric sheet being fixed to the disk and thereby held in position in said envelope, said insulating member comprising a thin disk of mica.

5. In a negative glow display device an elongated envelope, a press within said envelope at one end thereof, a thin mica disk at the other end thereof, the edge of the mica disk being engaged with the inner wall of the envelope an electrode assembly comprising a plurality of spaced electrodes and supporting means therefor extending from said press to said disk and supported by the press and disk.

6. In a negative glow display, an elongated envelope, an electrode assembly in said envelope, and means supporting said assembly in spaced relation to the walls of the envelope, said supporting means including a transparent support at one end of the envelope through which the display is visible.

7. In a negative glow device, an envelope, a plurality of electrodes in said envelope, a pair of spaced dielectric sheets of substantial area within said envelope, part of said electrodes being mounted on one of said sheets and part of said electrodes being mounted on the other sheet whereby each sheet supports its electrode in spaced relation with respect to the envelope, a spacing member secured to both of said sheets and holding them in spaced relation, said electrodes having extensions at their opposite edges which are bent over the sheets to thereby secure the electrodes to the sheets.

ANDREW F. HENNINGER, Jr.