

(No Model.)

F. THONE.

INCANDESCENT LAMP SOCKET.

No. 379,255.

Patented Mar. 13, 1888.

Fig. 1.

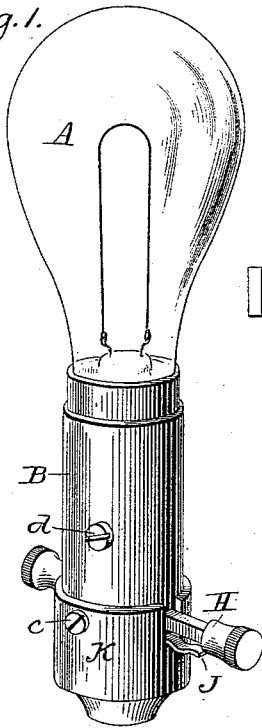

Fig. 2.

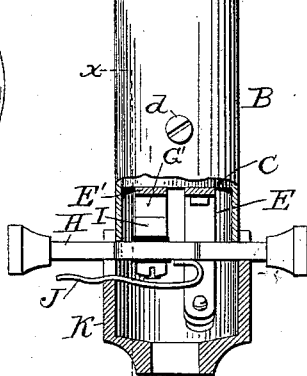

Fig. 3.

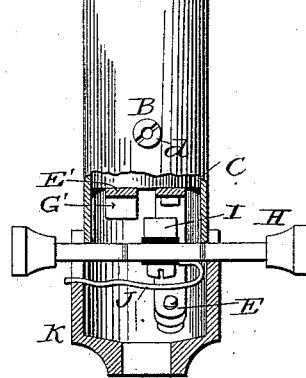

Fig. 4.

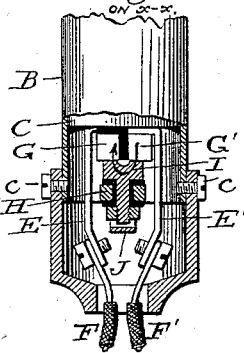

Fig. 5.

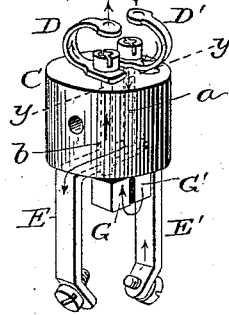

Fig. 6.

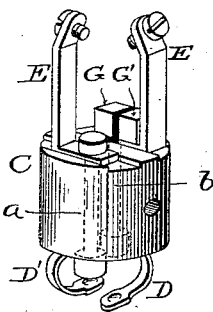

Fig. 7.

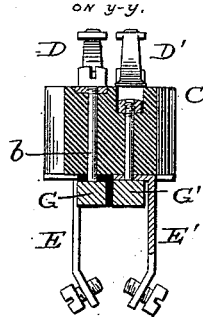
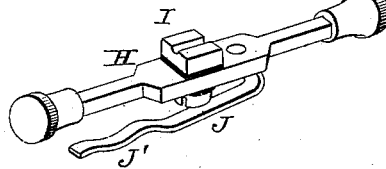

Fig. 8.



Witnesses:

James F. DuKamel  
Walter S. Dodge.

Frank Thone,  
Inventor,

by Dodget Son,

his Attys.

# UNITED STATES PATENT OFFICE.

FRANK THONE, OF OSKALOOSA, IOWA.

## INCANDESCENT-LAMP SOCKET.

SPECIFICATION forming part of Letters Patent No. 379,255, dated March 13, 1888.

Application filed February 16, 1887. Serial No. 227,822. (No model.)

*To all whom it may concern:*

Be it known that I, FRANK THONE, of Oskaloosa, in the county of Mahaska and State of Iowa, have invented certain new and useful  
5 Improvements in Incandescent Lamps, of which the following is a specification.

My invention has reference to incandescent electric lamps; and it consists in a novel construction of the socket or holder thereof, as  
10 hereinafter fully set forth and claimed.

In the drawings, Figure 1 is a perspective view of a lamp provided with my improved socket or holder; Figs. 2 and 3, side views of the socket or holder broken away to show the  
15 interior; Fig. 4, a sectional view on the line *xx* of Fig. 2; Fig. 5, a perspective sectional view showing the internal construction of the holder; Fig. 6, a perspective view, from the opposite end, of the devices shown in Fig. 5; Fig.  
20 7, a vertical sectional view on the line *yy* of Fig. 5, and Fig. 8 a perspective view of the switch bar or slide.

The present invention has for its object to simplify and cheapen the construction of the  
25 holders or sockets, and at the same time to produce a switch or circuit controller that may be easily operated.

In carrying out my invention I adopt the construction shown in the drawings, in which—  
30 A indicates the globe, which will be provided with a light-giving filament of any suitable material, said filament being connected at its ends with wires, as is usual in this class of  
35 lamps. These wires project out through the closed bottom of the globe, and are provided with suitable contact-points, which latter are arranged to touch and make contact with suitable contact-arms secured within the socket or  
40 holder.

The construction of the globe, its filament, conductors or wires, and contact-points forms  
45 no part of my invention; and as the construction of said devices is well known to those skilled in the art and susceptible of considerable variation, I have not deemed it necessary to either show or describe such parts in detail.

The socket or holder comprises a cylindrical case or shell, B, provided with an internal non-conducting block or plug, C, carrying on its  
50 upper face metallic arms D D', arranged to make contact with the contact-points of the lamp, and on its under face arms E E', to which the line or circuit wires F and F' are secured, as clearly shown in Figs. 5, 6, and 7.

Arm D' is electrically connected by means 55 of a bolt or stem, *a*, with the arm E, while the other contact-arm, D, is electrically connected by means of a bolt or stem, *b*, with a contact-block, G, secured to the under side of the plug or block C, as shown in Fig. 7. A similar contact-block, G', is also secured to the under side  
60 of block C; and upon reference to Figs. 4, 5, 6, and 7 it will be noticed that said block, while electrically connected with arm E', is insulated from block G. The incoming wire F' is secured  
65 to the arm E', and when the circuit is completed by means of a bridging piece the current will pass through arm E', blocks G G', and bolt *b*, contact-arm D, through the lamp, and thence back by contact-arm D', bolt *a*, and arm  
70 E and wire F.

As shown in Figs. 1, 2, and 3, the case or shell B has slots in its sides, through which project the ends of a sliding bar or rod, H,  
75 carrying on its upper face a block, I, of such width as to reach from block G to block G' and electrically connect said blocks, thereby completing the circuit and establishing a current through the lamp. The bar or slide H is  
80 shown in such position in Figs. 2 and 4; but in Fig. 3 it is shown in position to cut out the lamp or break the circuit, the block I, carried by said bar or slide, being moved away from and out of contact with the blocks G G'.

Slide or bar H carries on its under face 85 a spring, J, which, as shown in Figs. 2 and 3, bears at one end in the slot in the shell B, the spring being formed with a V-shaped portion, J', the apex of which, riding over the wall of the slot, holds the spring, and consequently  
90 the slide, in whichever position it may be placed.

When it is desired to complete the circuit, the slide H is pushed over to the position indicated in Figs. 2 and 4, so that the blocks I  
95 carried thereby will touch both the blocks G and G'. The current will then pass from arm E' to block G', through block I to block G, thence to contact arm D and into the lamp, the current returning by means of contact-arm  
100 D', stem or bolt *a*, and arm E. As shown in Fig. 4, the contact-block I, carried by the rod or bar H, is completely insulated therefrom. The lower end of the shell or case B is provided with a removable cap, K, as shown in  
105 Figs. 1, 2, 3, and 4, by removing which access may be had to the lower end of the case B, and which also forms a convenient means for at-

tachment of the lamp as a whole to its supporting-bracket.

The cap K may be retained in place by screws *c c*, Figs. 1 and 4, or in any other convenient manner.

The case or shell B and its cap K may be made of sheet or cast metal, as is preferred, and may be made more or less ornamental in appearance.

The manner or means of attaching the globe to the socket or holder is likewise a matter susceptible of considerable variation, and I do not restrict myself to the use of any particular construction of joint or connection for this purpose, the upper part of the shell or case being made to receive any particular lamp desired.

The block or plug C, to which are attached the contact-arms D D', arms E E', and contact-blocks G G', is made, preferably, of vulcanized or compressed fiber, and is held in its place by means of a bolt or screw, *d*, passing through the shell B and the plug C from side to side; but of course any other means may be employed for retaining it in place.

By removing the screw or bolt *d* the plug C and all parts attached thereto may be removed from the case or shell B, thus greatly facilitating the assembling or repair of parts.

It will be observed that the slide or bar H, as represented in the drawings, projects through the shell B on both sides, so that the said bar may be operated from either side of the lamp at will; and it will be seen that very slight force is required to move the bar to make and break the circuit.

By constant use of the switch bar or slide H the contact points or blocks G, G', and I keep their opposing faces bright and clean by moving over and against each other, and thereby insure a proper connection for the current.

Instead of making the contact-block G' separate from the arm E', it may be made integral therewith.

It is also obvious that the block C may be made of glass, porcelain, gutta-percha, or any other suitable non-conducting material.

The slide or bar H need not necessarily project from the shell or case at both ends, but may project at one end only, though I prefer the construction shown and described.

The switch, consisting of the bar or slide H with its block I and the contact-blocks G G', may obviously be used to make or break a circuit elsewhere than in the lamp-socket, and may control either the main line or circuit including a group or series of lamps, or, in fact, any electric circuit, though more particularly designed for use in the socket as above set forth.

Having thus described my invention, what I claim is—

1. In a socket or holder for incandescent electric lamps, the combination of a shell or case, a non-conducting plug or block, as C, provided on its upper face with contact-arms D D' and on its under face with arms E E' and

contact-blocks G G', and a slide, as H, provided with a block, I, all substantially as shown.

2. In combination with a lamp proper and the shell or case B, plug C, provided with arms D D', arranged to make contact with the terminals of the lamp-filament, conducting-arms E E', also secured to said plug C, a stem or bolt, *a*, connecting arms E and D', a contact-block, G, electrically connected with the arm D, and a switch-bar arranged, substantially as shown, to electrically connect the arm E' and the block G and thereby complete the circuit through the lamp.

3. In combination with the lamp and the case or shell B, a non-conducting plug, C, secured within the shell or case and provided on its upper face with contact-arms D D' and on its under face with conductor-arms E E', the arms D D' and E E' forming a normally-open circuit, and a switch bar or rod arranged to complete the circuit, substantially as shown.

4. In combination with the lamp and the case or shell B, a non-conducting plug, C, secured within the latter, arms D D' upon the upper face of said plug, arms E E', for attachment of the conductors, secured to the under side of the plug C, one of the arms, E, being connected with one of the contact-arms, D', a block, as G, upon the under side of plug C, connected with contact arm D, and a switch-bar, H, arranged to electrically connect the block G with the arm E', all substantially as shown.

5. In an electric lamp, the combination, with the socket or holder provided with suitable conductors, of the sliding bar or slide H, provided with the insulated bridge or block I, arranged, substantially as shown, to make or break the circuit as said rod is moved back and forth through the socket.

6. In an electric lamp, the combination, with the socket or holder provided with suitable conductors, of the sliding bar or rod H, provided with the block I and spring J.

7. In an electric lamp, the combination, with the socket or holder provided with a non-conducting plug, C, of conductors D D' and E E', arranged at opposite ends of said plug and connected in pairs, a fixed contact-block, G, and a bar or slide arranged to bring said block G into the circuit.

8. A socket for incandescent lamps provided with electrical conductors for connection with the terminals of a lamp and with the line, and a slide movable longitudinally across the shell or case of the socket and provided with an insulated block to connect the conductors, substantially as shown and described.

In witness whereof I hereunto set my hand in the presence of two witnesses.

FRANK THONE.

Witnesses:

H. C. TURNER,  
J. S. WHARTON.